



Dust
TROMB 60

TROMB

New DC Tromb 600 Longopac

Control Part no 4313

FILTER

DC Tromb 600 Longopac



The DC Tromb 600 is our most powerful single-phase dust extractor. It is designed to meet modern safety requirements and to work in conjunction with tools that have become ever more efficient and therefore produce more dust than they have previously. The maximum airflow is as high as 600 m³/h = 353 cfm, which is more than enough capacity for equipment such as large floor grinders and large electric cut-off saws.

Not only is the DC Tromb 600 compact, powerful and efficient, but it's versatile too. It is easy to transport around construction sites, move in stair-wells and lift into tight spaces. The wheels are puncture-proof and won't leave marks on the floor. The front wheels are lockable for working on uneven ground. The DC Tromb 600 is adapted for all types of fine dust such as concrete (silica), plaster, wood and filler dust.

The machine comes equipped as standard with a fine filter (rinsable polyester) and an HEPA H13 filter that complies with OSHA regulations. A filter monitor shows the user when it's time to clean the filter. Filter cleaning can be done automatically during operation, or once the work has been completed.

Technical Data

HxWxD [mm/in]	1600x600x800 /63x24x31
Weight [kg/lb]	65/143
Collection container [l/gal]	L) Longopac
Flow max, fan, EU/US [m ³ /h/cfm]	600/353
Negative pressure, max, EU/US [kPa/inwg]	21 +/- 10%
Power 230V /50Hz /60Hz [W]	4050

Supplied with (Part No)

Connecting sleeve (2129)
Coupling socket (2008)
Suction hose antistatic (Ø50 mm /2") 5 m/16 ft (2013)
Floor nozzle B500 mm /W 19.7" (7238)
Suction pipe (Ø50 mm /2") (7265)
Fine filter, polyester (44017-2)
HEPA H13 filter (44016-1)

DC Tromb 600 Longopac (Part No) 181532

Accessories to go with your DC Tromb 600 Longopac



44016-1 HEPA H 13 filter
made of cellulose and fibreglass



44017-2 Fine filter
made of polyester



432177 Longopac plastic bags, 23 m /75 ft. Set of 4.



New features!

- Easier filter change procedure.
- Tall cyclone & sturdy chassis.
- Quick coupling for filter change.
- Equipped with a HEPA H13 and a washable polyester filter.
- Semi automatic filter cleaning.

Quick Response code for more info!



Scan the QR code and get more information about the different DC Tromb models, videos, guidelines and much more.

Equipped with the Highest filtration!



All our mobile machines are equipped with a fine filter and a HEPA filter (H13) that clean the exhaust air to 99.95 %. These high-efficiency filters also have a long service life, which not only results in cleaner air, but also low filter costs.

The filter systems comply with the OSHA regulation, Annex AA, H-class, EN 60335-2-69.

New DC Tromb 600 Longopac

Efficient, powerful, ergonomic and flexible!

More features!

Semi-automatic filtration system.

Flexible cylinder head for HEPA H13 filters that facilitate service and maintenance.

An easier-to-remove cyclone for efficient maintenance during service or repair.

High quality and robust chassis.

Robust and flexible suction-pipe holder.



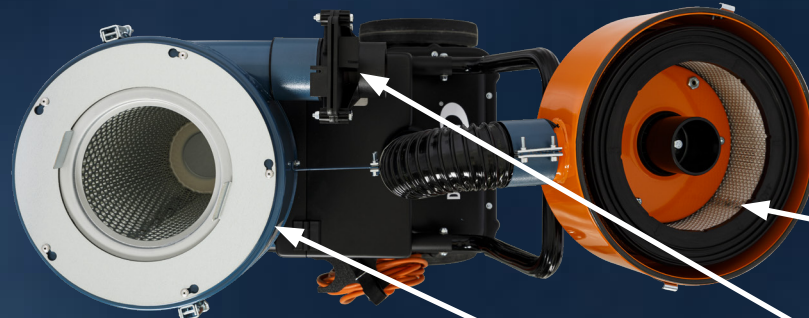

Microfilter/ HEPA H13 filter.

Protected shutter valve.

Locking ring for pre-filter.

Accordion hose for easier handling when changing filters.

Improved cable suspension.

New engine package for easier handling of service.

www.dustcontrol.us

Dustcontrol Inc, US Headquarters, Wilmington North Carolina, 6720 Amsterdam Way, Wilmington, NC 28405

